

# CE-10xx Non-insulation type DC-DC converter

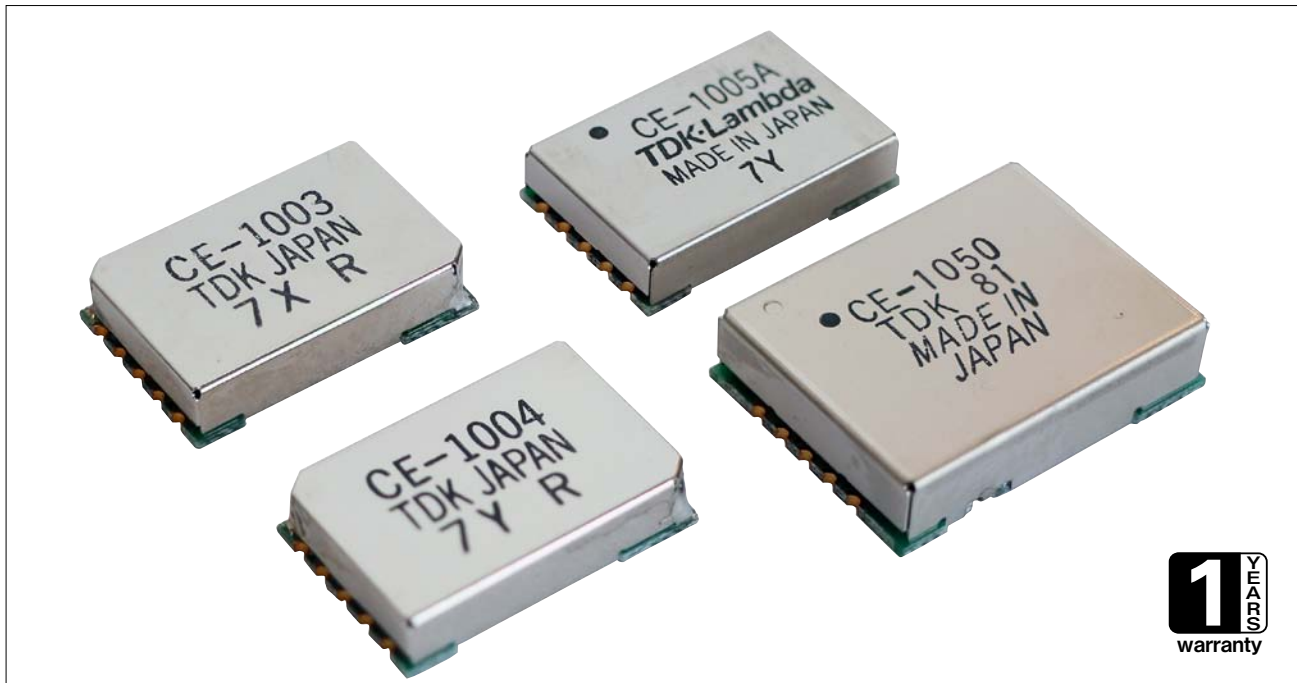

## ■ Features

- SMD type
- Short in height (CE-1003/1004: 4.5mm, CE-1005A: 4.2mm, CE-1050: 5.5mm)
- Wide range of operating temperature conditions: -40°C - +85°C (CE-1050: -20°C - +85°C)
- Equipped with Remote On/Off function
- Equipped with Variable output voltage function
- 5-side metal-shielded low noise design
- Delivery in tray or by taping available
- CE-1005A is high efficiency than CE-1005

## ■ Model-naming method

### CE-1003-TP

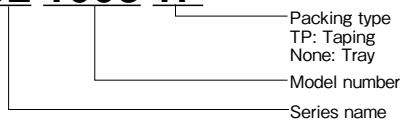

## ■ Applications

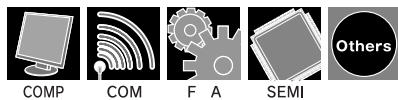

## ■ Conformity to RoHS Directive

This means that, in conformity with EU Directive 2002/95/EC, lead, cadmium, mercury, hexavalent chromium, and specific bromine-based flame retardants, PBB and PBDE, have not been used, except for exempted applications.

## ■ Product Line up

| Model name          | CE-1003             | CE-1004             | CE-1005A  | CE-1050  |
|---------------------|---------------------|---------------------|-----------|----------|
| Input voltage (V)   | Output voltage+4-16 | Output voltage+4-16 | 3.00-5.25 | 9.0-26.4 |
| Output voltage (V)  | 1.5-3.3             | 3.3-5.0             | 0.9-3.3   | 3.3-12.6 |
| Output current (mA) | 1500                | 1500                | 2500      | 2500     |

# CE-1003, -1004 Specifications

| ITEMS/UNITS |                                     | MODEL | CE-1003   | CE-1004 |
|-------------|-------------------------------------|-------|---|---------|
| Input       | Nominal Voltage                     | V     | DC12  |         |
|             | Voltage Range                       | V     | Vout+4V ~ DC16V   |         |
|             | Efficiency (min/typ) (*1)           | %     | 83/88   | 85/90   |
| Output      | Maximum Current (*2)                | A     | 1.5   |         |
|             | Voltage Setting Accuracy (max) (*3) | %     | ± 3   |         |
|             | Total Regulation (max)              | %     | ± 5   |         |
|             | Ripple Voltage (max/typ) (*4)       | mVp-p | 100/30  |         |
|             | Voltage Adjustable Range (*5)       | VDC   | 1.5-3.3   | 3.3-5.0 |
| Function    | Over Current Protection (typ) (*6)  | A     | 2   |         |
|             | Over Voltage Protection             |       | Not available   |         |
|             | Remote ON/OFF Control (*7)          |       | Available   |         |
| Environment | Operating Ambient Temperature       | °C    | -40 to +85  |         |
|             | Storage Ambient Temperature         | °C    | -40 to +85  |         |
|             | Operating Ambient Humidity          | % RH  | 10-90 (the conditions of maximum 38°C in wet bulb temperature and non-condensation should be ensured.)                                      |         |
|             | Storage Ambient Humidity            | % RH  | 10-90 (the conditions of maximum 38°C in wet bulb temperature and non-condensation should be ensured.)                                      |         |
|             | Vibration CE-1003                   |       | 10-2000Hz, 4 minutes sweep and 98m/s <sup>2</sup> (10G) acceleration, 3 directions, 0.5h for each, in non-operation                         |         |
|             | Vibration CE-1004                   |       | 10-500Hz, 1 minutes sweep and 98m/s <sup>2</sup> (10G) acceleration or 1.5mm total amplitude, 3 directions, 0.5h for each, in non-operation |         |
|             | Shock                               |       | 980m/s <sup>2</sup> (100G), 6ms, 3 directions, 3 times for each, in non-operation   |         |
| Mechanical  | Weight                              | g     | 1.8   |         |
|             | Size (W x H x D)                    | mm    | 18.3 x 4.5 x 12.3   |         |

(\*1) In CE-1003: Vin=12V, Io=0.5A, Vout setting = 3.3V, Ta=25°C.  
 In CE-1004: Vin=12V, Io=0.5A, Vout setting = 5.0V, Ta=25°C.

(\*2) Derating is needed when in use at CE-1003: 70°C or higher.  
 CE-1004: No derating is needed.

(\*3) In Vin=12V, Io=0.5A, Ta=25°C.

(\*4) In 20MHz, Ta=25°C.

(\*5) 4V or higher difference between the input and output voltage is needed.

(\*6) Automatically resumes when output current becomes 0.5A or less.

(\*7) On voltage: 6V max. - 2V min., Off voltage: 0.6V max. - 0V min.

With nominal input/output voltage, maximum output current, and Ta=25°C, if not specified separately.

## Outline Drawing

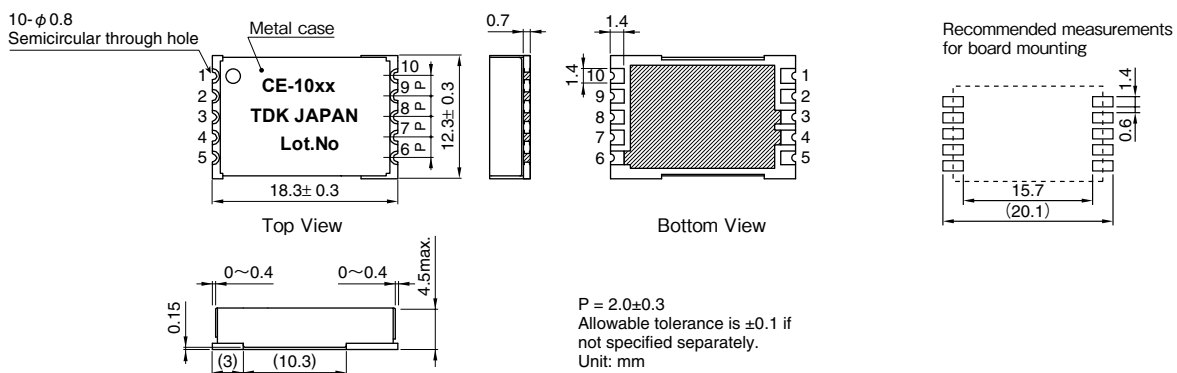

## Derating Curve

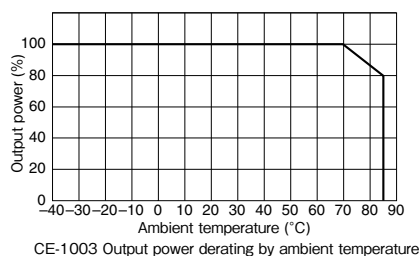

# CE-1005A Specifications

| ITEMS/UNITS |                                    | MODEL | CE-1005A  |
|-------------|------------------------------------|-------|---|
| Input       | Nominal Voltage                    | V     | DC3.3/5.0   |
|             | Voltage Range                      | V     | DC3.0-5.25  |
|             | Efficiency (min/typ) (*1)          | %     | 88.0/93.0   |
| Output      | Maximum Current                    | A     | 2.5   |
|             | Voltage Setting Accuracy (max)(*2) | %     | ± 3   |
|             | Total Regulation (max)             | %     | ± 4   |
|             | Ripple Voltage (max/typ) (*3)      | mVp-p | 50/20   |
|             | Voltage Adjustable Range(*4)       | VDC   | 0.9-3.3   |
| Function    | Short Circuit Protection (*5)      |       | Available   |
|             | Over Voltage Protection            |       | Not available   |
|             | Remote ON/OFF Control (*6)         |       | Available   |
| Environment | Operating Ambient Temperature      | °C    | -40 to +85  |
|             | Storage Ambient Temperature        | °C    | -40 to +85  |
|             | Operating Ambient Humidity         | % RH  | 10-90 (the conditions of maximum 38°C in wet bulb temperature and non-condensation should be ensured.)              |
|             | Storage Ambient Humidity           | % RH  | 10-90 (the conditions of maximum 38°C in wet bulb temperature and non-condensation should be ensured.)              |
|             | Vibration                          |       | 10-2000Hz, 4 minutes sweep and 98m/s <sup>2</sup> (10G) acceleration, 3 directions, 0.5h for each, in non-operation |
|             | Shock                              |       | 980m/s <sup>2</sup> (100G), 6ms, 3 directions, 3 times for each, in non-operation                                   |
| Mechanical  | Weight                             | g     | 1.5   |
|             | Size (W x H x D)                   | mm    | 18.3 x 4.2 x 12.3   |

- (\*1) Vin=5V, Io=2.5A, Vout=3.3V, Ta=25°C.
- (\*2) Vin=5V, Io=2.5A, Ta=25°C.
- (\*3) 100MHz, Ta=25°C.
- (\*4) Output is 0.9-3.3V when input is 4.5-5.25V. Output is 0.9-2.5V when input 3.0-4.5V.
- (\*5) Output will be shut down by detecting over current when output is in short circuit situation.  
Output will be restarted when output is not in short circuit situation.
- (\*6) ON voltage: 0.5Vmax./0Vmin. OFF voltage: 2Vmin./Vin.max.

With nominal input/output voltage, maximum output current, and Ta=25°C, if not specified separately.

# Outline Drawing

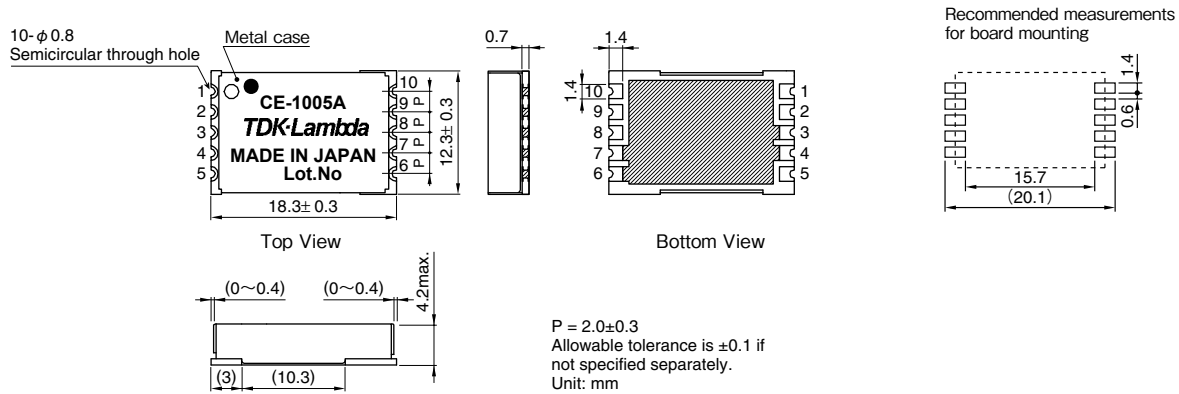

# CE-1050 Specifications

| ITEMS/UNITS |  | MODEL | CE-1050   |
|-------------|--|-------|---|
| Input       | Voltage Range                                  | V     | DC9.0-26.4  |
|             | Efficiency (min/typ) (*1)                      | %     | 85/90   |
| Output      | Maximum Current (*2)                           | A     | 2.5   |
|             | Total Regulation (3.3V ≤ Vo ≤ 5V) (max)        | %     | ± 3.5   |
|             | Total Regulation (5V < Vo ≤ 12.6V) (max)       | %     | ± 5.0   |
|             | Ripple Voltage (3.3V ≤ Vo ≤ 5V) (max/typ) (*3) | mVp-p | 50/25   |
|             | Ripple Voltage (5V < Vo ≤ 12.6V) (*3)          | mVp-p | 100/50  |
|             | Voltage Adjustable Range (*4)                  | VDC   | 3.3-12.6  |
| Function    | Over Current Protection (typ) (*5)             | A     | 3.5   |
|             | Over Voltage Protection                        |       | Not available   |
|             | Remote ON/OFF Control (*6)                     |       | Available   |
| Environment | Operating Temperature                          | °C    | -20 to +85  |
|             | Storage Temperature                            | °C    | -40 to +85  |
|             | Operating Humidity                             | % RH  | 10-90 (the conditions of maximum 38°C in wet bulb temperature and non-condensation should be ensured.)                                      |
|             | Storage Humidity                               | % RH  | 10-90 (the conditions of maximum 38°C in wet bulb temperature and non-condensation should be ensured.)                                      |
|             | Vibration                                      |       | 10-500Hz, 1 minutes sweep and 98m/s <sup>2</sup> (10G) acceleration or 1.5mm total amplitude, 3 directions, 0.5h for each, in non-operation |
|             | Shock  |       | 980m/s <sup>2</sup> (100G), 6ms, 3 directions, 3 times for each, in non-operation   |
| Mechanical  | Weight   | g     | 3.74  |
|             | Size (W x H x D)                               | mm    | 21.3 x 5.5 x 17.7   |

- (\*1) With 18V input voltage, 5V output voltage, and 2.5A output current.
- (\*2) Derating is needed depending on the ambient temperature and the input voltage.
- (\*3) In 20MHz, Ta=25°C, Vin=18V.
- (\*4) 4V or higher difference between the input and output voltage is needed.
- (\*5) Automatically resumes when output current becomes 1A or less.
- (\*6) On voltage: 6V max. - 3V min., Off voltage: 0.4V max. - 0V min.

With nominal input/output voltage, maximum output current, and Ta=25°C, if not specified separately.

## Outline Drawing

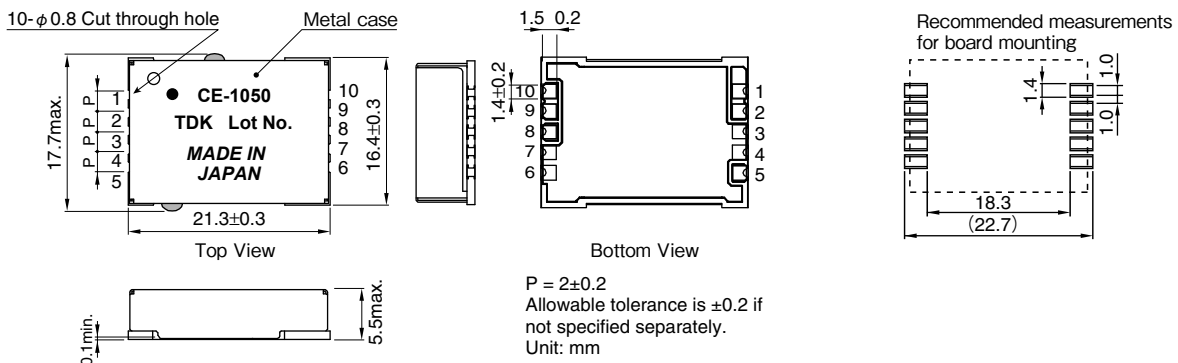

## Derating Curve

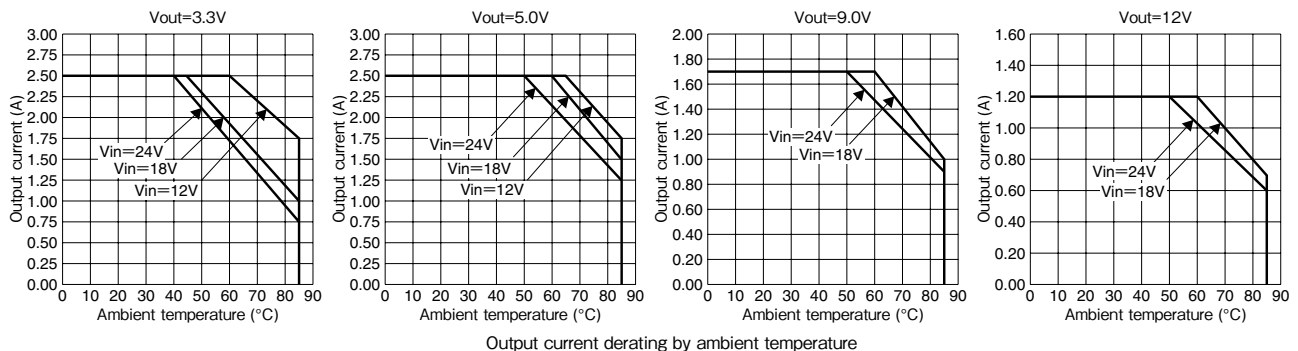

• All specifications are subject to change without notice.

# Instruction Manual

## 1. CE-1003, -1004

### 1-1. Connection diagram

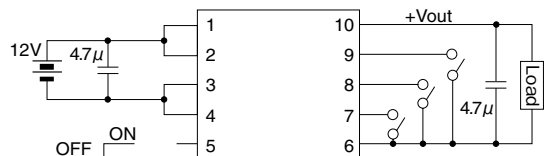

### 1-4. Start-up and operating conditions

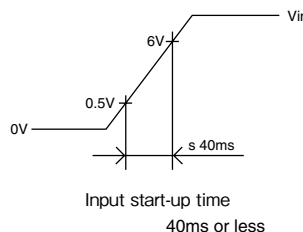

### 1-2. Terminal connections

| Number | CE-1003, -1004 |
|--------|----------------|
| 1      | Vin            |
| 2      | Vin            |
| 3      | GND            |
| 4      | GND            |
| 5      | ON/OFF         |
| 6      | GND            |
| 7      | Vs-0           |
| 8      | Vs-1           |
| 9      | Vs-2           |
| 10     | Vout           |

Input-side inductance

Lin : 2.2µH or lower •• When adding inductance, add input capacitor Cin simultaneously.

Input-side capacitance

Cin : Lin x 10 or higher •• Capacitance of the added capacitor should be 10 times or over the Lin value (Maximum ripple voltage may increase).

Output-side added capacitance

Cout : 100µF or lower •• Start-up may not be possible if the capacitance is high.

### 1-3. Output voltage setting method

To change the output voltage, short-circuit between the pins as shown below according to the voltage to be set.

| Vout    |         | Pin 7 | Pin 8 | Pin 9 |
|---------|---------|-------|-------|-------|
| CE-1003 | CE-1004 |       |       |       |
| 3.3V    | 5.0V    | 0     | 0     | 0     |
| 3.0V    | 4.8V    | 0     | 0     | 1     |
| 2.8V    | 4.5V    | 0     | 1     | 0     |
| 2.5V    | 4.3V    | 0     | 1     | 1     |
| 2.3V    | 4.0V    | 1     | 0     | 0     |
| 2.0V    | 3.8V    | 1     | 0     | 1     |
| 1.8V    | 3.5V    | 1     | 1     | 0     |
| 1.5V    | 3.3V    | 1     | 1     | 1     |

0 : Short-circuited to GND  
1 : OPEN

### 1-5. Protection functions

Over output current protection is incorporated. If a current over the set value for the protection circuit flows, the output is lowered. It resumes automatically by lowering load current to 0.5A. (Start-up may not be possible in constant current load. Load current in start-up should be 0.5A or lower.)

## 2. CE-1005A

### 2-1. Connection diagram

- To raise output voltage above 1V: Inserting Rex between 7 pin and 8 pin

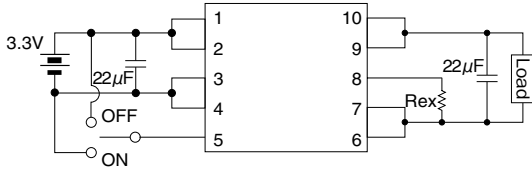

- To lower output voltage below 1V: Inserting Rex between 8 pin and 9 pin

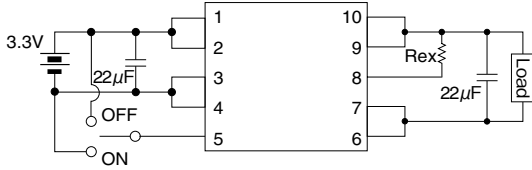

When in use with 1V output voltage, Rex does not need to be attached. (Set 8 pin to open.)

### 2-2. Terminal connections

| Number | CE-1005A |
|--------|----------|
| 1      | Vin      |
| 2      | Vin      |
| 3      | GND      |
| 4      | GND      |
| 5      | ON/OFF   |
| 6      | GND      |
| 7      | GND      |
| 8      | Vset     |
| 9      | Vout     |
| 10     | Vout     |

### 2-3. Output voltage setting method

To change the output voltage from 1V, calculate Rex by assigning the absolute value of the output voltage to Vout in the expression below, and attach it between the terminals to be connected.

When in use with 1V output voltage, Rex does not need to be attached (Set 8 pin to open.).

| Set voltage                | Terminals to be connected | Expression  |
|----------------------------|---------------------------|---|
| $1V < V_{out} \leq 3.3V$   | 7-8                       | $R_{ex} = \frac{18.3 - 5.1 \times V_{out}}{V_{out} - 1}$  |
| $0.9V \leq V_{out} < 1.0V$ | 8-9                       | $R_{ex} = \frac{27.1 \times V_{out} - 18.3}{1 - V_{out}}$ |

Unit: V, kΩ

### 2-4. Start-up and operating conditions

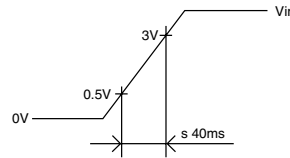

Input power supply start-up time  
40ms or less

Input-side inductance

Lin : 4.7µH or lower•• When adding inductance, add input capacitor Cin simultaneously.

Input-side capacitance

Cin : Lin x 10 or higher•• Capacitance of the added capacitor should be 10 times or over the Lin value (Maximum ripple voltage may increase).

Output-side added capacitance

Cout : 100µF or lower•• Start-up may not be possible if the capacitance is high.

### 2-5. Protection functions

Over output current protection is incorporated. When a short circuit state was removed, returns to normal.

### 2-6. Difference with CE-1005

- Efficiency up (75⇒85% Vin=3.3V Vo=1V/1.5A)
- An output low noise (40⇒18mV Vin=3.3V Vo=1V/1.5A)
- Output voltage variable range expansion (1 to 3.3⇒0.9 to 3.3V)
- The initial output voltage value(2.5⇒1.0V)
- There is no temperature derating by the output voltage
- Product weight 12% reduction(1.7⇒1.5g)
- Oscillation frequency(550k⇒600kHz fixed)

# 3. CE-1050

### 3-1. Connection diagram

• To raise output voltage above 5V: Inserting Rex between 7 pin and 8 pin

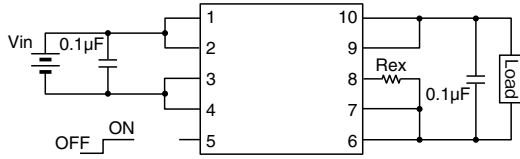

• To lower output voltage below 5V: Inserting Rex between 8 pin and 9 pin

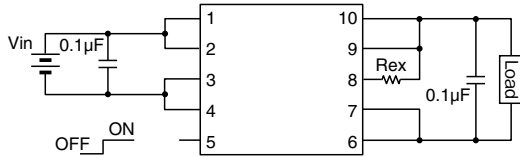

When in use with 5V output voltage, Rex does not need to be attached. (Set 8 pin to open.)

Output can be started and stopped by controlling no. 5 terminal. As this pin is pulled up by 2µA internal current source, the start-up time can be delayed by connecting a capacitor. Delay time is approximately 3ms per 1000pF.

### 3-2. Terminal connections

| Number | Symbol |
|--------|--------|
| 1      | Vin    |
| 2      | Vin    |
| 3      | GND    |
| 4      | GND    |
| 5      | ON/OFF |
| 6      | GND    |
| 7      | GND    |
| 8      | Vset   |
| 9      | Vout   |
| 10     | Vout   |

### 3-3. Output voltage setting method

To change the output voltage from 5V, calculate Rex by assigning the absolute value of the output voltage to Vout in the expression below, and attach it between the terminals to be connected. When in use with 5V output voltage, Rex does not need to be attached (Set 8 pin to open).

| Set voltage               | Terminals to be connected | Expression  |
|---------------------------|---------------------------|---|
| $5V < V_{out} \leq 12.6V$ | 7-8                       | $R_{ex} = \frac{13.31 - V_{out}}{V_{out} - 5}$            |
| $3.3V \leq V_{out} < 5V$  | 8-9                       | $R_{ex} = \frac{7.8 \times V_{out} - 13.31}{5 - V_{out}}$ |

Unit: V, kΩ

### 3-4. Start-up and operating conditions

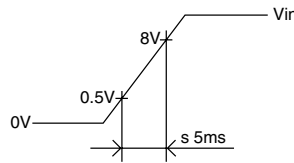

Input start-up time: 5ms or less

Input start-up time

Vin\_rs : 5ms or less • If this condition cannot be satisfied, use the On/Off terminal and start the unit in the condition with input voltage applied.

Input-side inductance

Lin : 2.2µH or lower • When adding inductance, add input capacitor Cin simultaneously.

Input-side capacitance

Cin : Lin x 10 or higher • Capacitance of the added capacitor should be 10 times or over the Lin value (Maximum ripple voltage may increase).

Output-side added capacitance

Cout : 100µF or lower • Start-up may not be possible if the capacitance is high. It is not recommended to add inductance to the output side.

### 3-5. Protection functions

Over output current protection is incorporated. If a current over the set value for the protection circuit flows, the output is lowered. The output resumes automatically when the load current is reduced to 1A or lower.

## 4. Notes on mounting and handling

- The connection diagrams in these handling instructions represent the standard connection methods for this product. Consult us for use with other connection methods.
- If the ripple voltage of the input power supply is high, or the ripple returned to input from the converter should be reduced, connect a capacitor with the appropriate capacity and an appropriate inductor, according to "Start-up and Operating Conditions" for each product in this instruction manual.
- If the maximum ripple & noise voltage should be reduced, connect a capacitor with appropriate capacity, according to "Start-up and Operating Conditions" for each product in this instruction manual.
- Series connection or parallel connection is not applicable for this product.
- Input fuse is not installed in this product.
- Do not use this product in an overload condition. Doing so can cause failure.
- Cleaning is not applicable for this product. Use low residue or non-cleaning flux.
- Notes on storage
  - ▶ Keep this product indoors with little temperature/humidity change and away from direct sunlight. Note that if this product is kept in a hot and humid condition or in a condition with drastic temperature changes, it can cause condensation, performance deterioration, or solderability deterioration.
  - ▶ CE-1050 uses multilevel boards. Observe the handling instructions described below. Otherwise, problems including pattern disconnection in reflow may occur (JEDEC MSL level 3).  
Baking process should be applied when 1 year or over has passed after delivery and the indicator value is 30% or over.  
Recommended baking conditions: 120°C, for 120 minutes, 1 time only
- \* Used tape is not heat-resistant.  
Baking should be processed after detaching products from the tape. Baking when leaving the tape attached causes a change in shape in the carrier tape.

### Recommended reflow soldering conditions

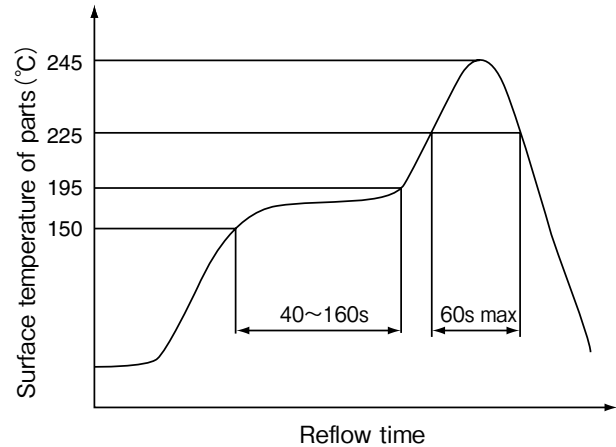

|                             |  |
|-----------------------------|--|
| Reflow frequency:           | 2 times (mounting on rear panel not allowed) |
| Preheating temperature:     | 150-195°C, 40-160s                           |
| Soldering temperature:      | 245°C or lower                               |
| Solder melting temperature: | 225°C or above, within 60s                   |
| Hand soldering:             | Within 380°C and 3s                          |